

Reducing CMC with a choke

By iw2fnd Lucio

Common Mode Currents (CMC)

Common Mode Currents (CMC) are the currents that flow in both conductors of the transmission line in the same direction and are the cause of radiofrequency radiation in the surrounding space. Reducing common mode current brings the currents flowing in the transmission line back into balance, leaving only the differential mode currents (CMD).

The reduction of CMC is achieved by inserting a blocking circuit in the loop through which the common mode current flows, in a way that it does not impede the flow of the differential mode current.

In practice, there are two types of blocking circuits commonly used:

- Parallel resonator, commonly referred to as an 'Ugly Bal-Un';
- Blocking inductance, commonly known as a 'Choke'.

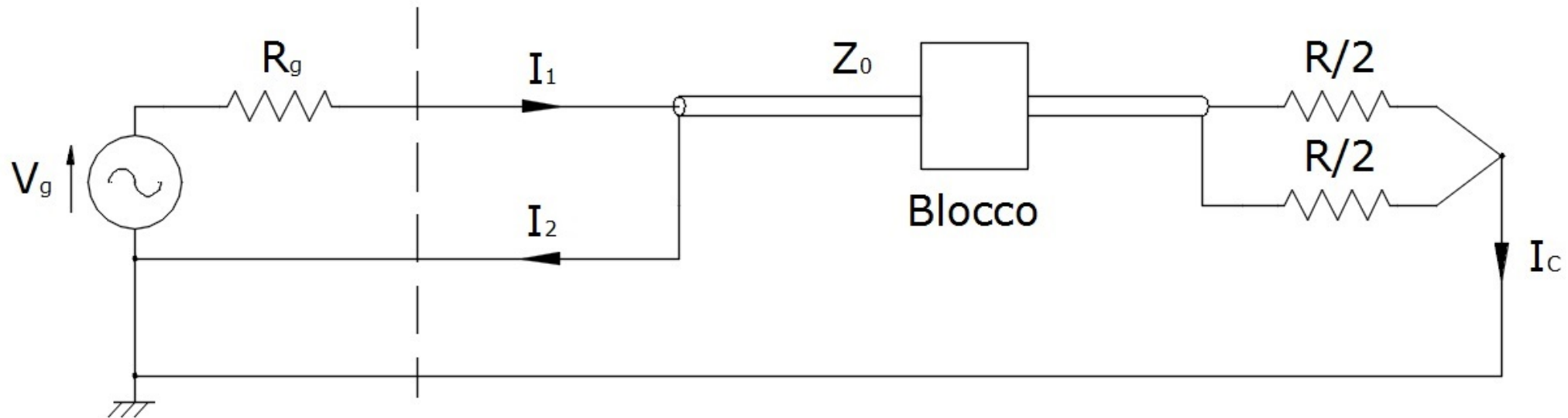

UGLY Bal-Un

The Ugly Bal-Un is a parallel resonator that is implemented by winding n turns of coaxial cable. In fact, the wound coaxial cable effectively acts as an air inductance, while the distributed capacitance created between the coaxial cable turns constitutes the parallel capacitor.

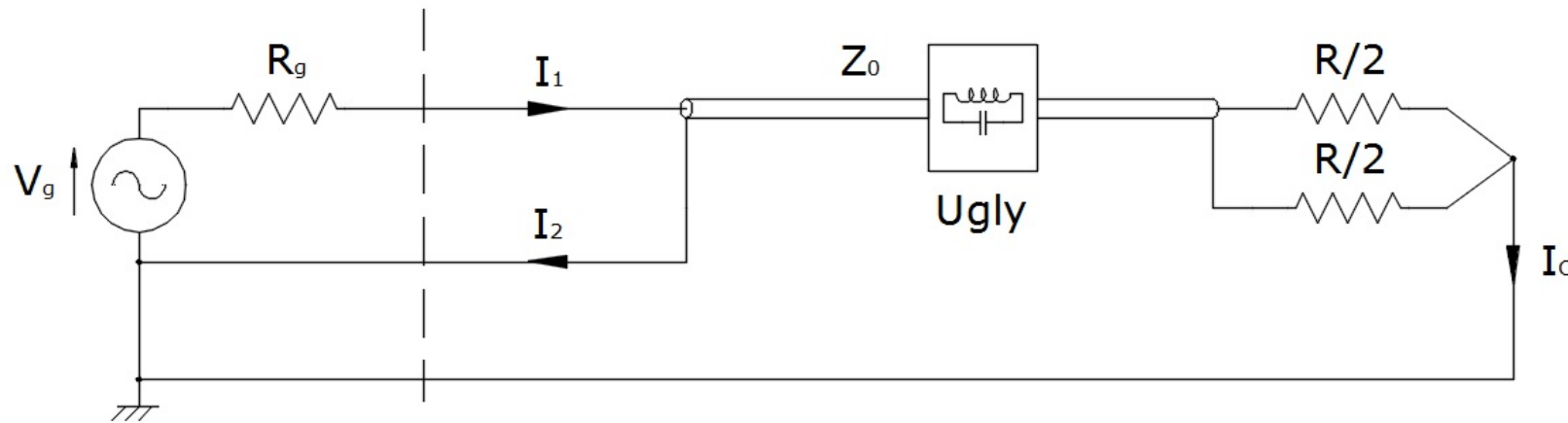

The blocking effect of such a circuit is very high at the resonance frequency because, typically, the circuit's Q is quite large. Unfortunately, its resonance frequency is influenced by installation and external environmental factors. Moreover, due to the high Q , these devices are not capable of effectively covering more than two or three frequency bands.

The difficulty in calibration and the uncertainty about its effectiveness make the Ugly Bal-Un less commonly used.

The 'choke'

A choke is a blocking inductance that is implemented by inserting an inductance along the path of the common mode current (CMC). Typically, this inductance is achieved by inserting ferrite sleeves along the line, or more conveniently, by winding the coaxial cable around a ferromagnetic material, such as a ferrite rod or a toroid.

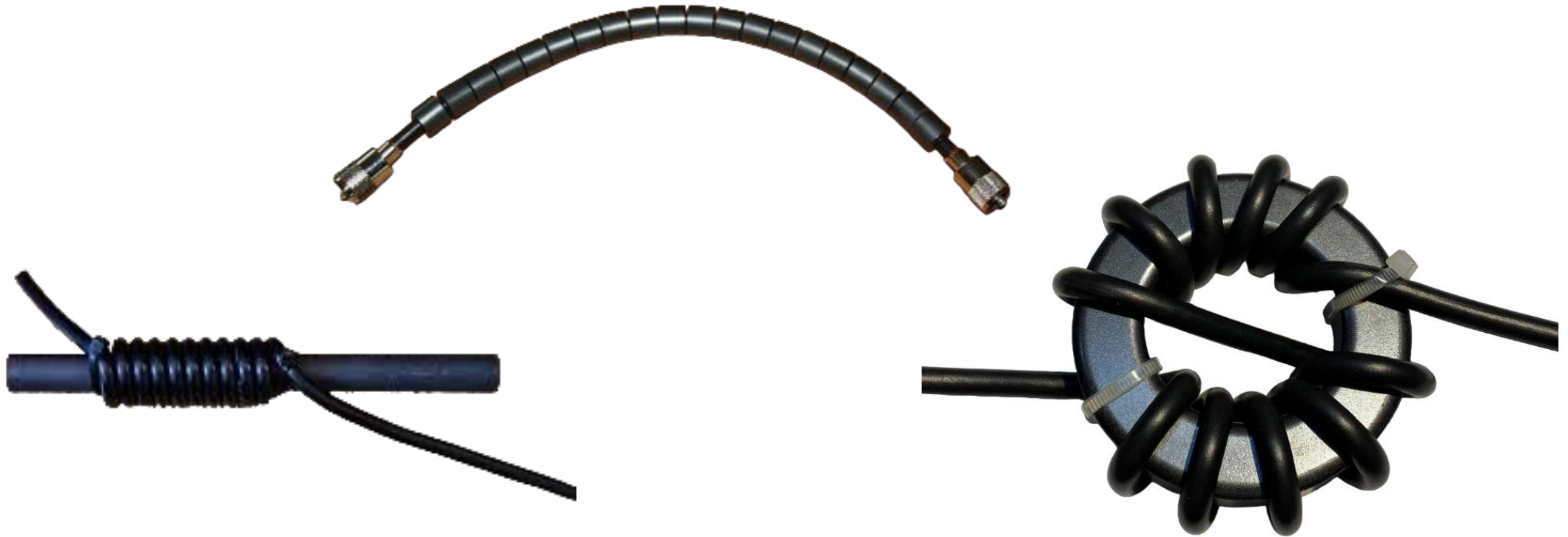

II choke

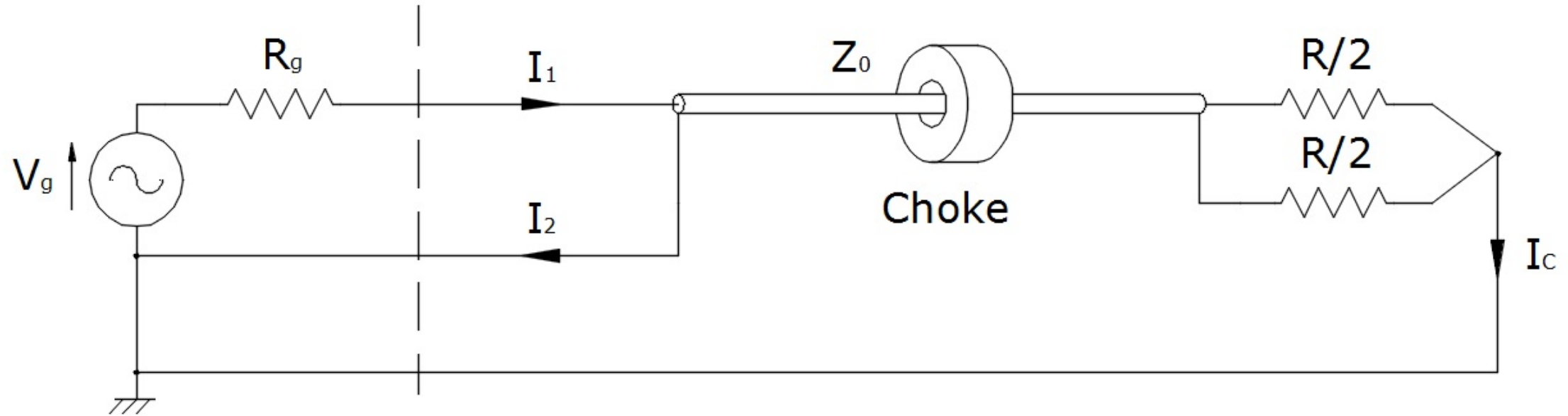

The blocking effect of a circuit made in this way is less pronounced than that of a resonant circuit, but it is not influenced by installation or external environmental factors. Moreover, the use of ferrite allows for the coverage of multiple frequency bands and sometimes even an entire frequency spectrum, such as in the case of HF.

In the video, we will discuss this type of choke, specifically those wound on ferrite toroids.

II choke

Inserting a choke along a transmission line is equivalent to inserting an inductance on both conductors. The inductance will ONLY affect common mode currents. In fact, the differential mode currents will only see the distributed inductance!

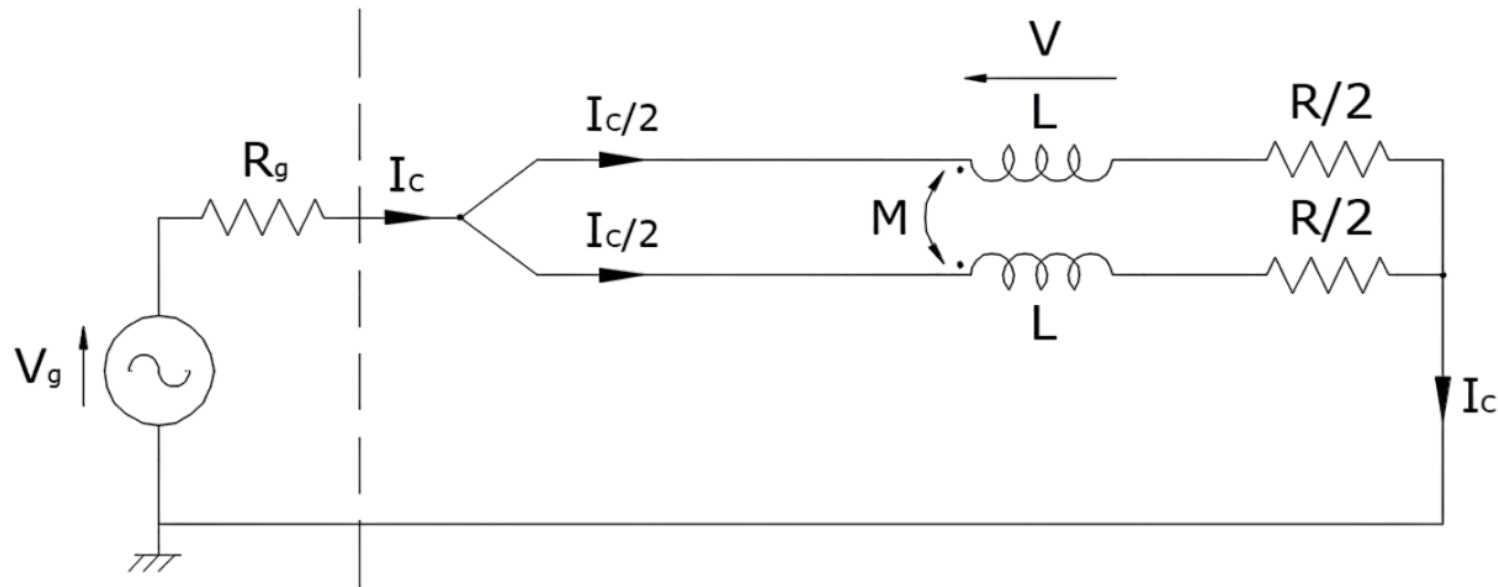

Usually, the common mode current, I_c , evenly splits between the two conductors of the line because the inductances L , produced by the choke, are equal and the load is balanced. Additionally, the coupling coefficient, k , of these inductances is very close to unity. As a result, the mutual inductance $M \approx L$ and the distributed inductance is very small. This is especially true when using coaxial cables, which is nearly always the case.

Implementation of the choke with a ferrite toroid.

1. Choosing the best ferrite;
2. Determining the minimum number of turns;
3. Selecting the coaxial cable;
4. Verifying the ferrite;
5. Creating the choke;
6. Testing the choke with a Vector Network Analyzer.

1) Choosing the best ferrite

The choice of ferrite is based on the frequency of use. Typically, ferrite with the highest magnetic permeability μ in the center of the band is selected. Remember that permeability

$$\mu = \sqrt{\mu'^2 + \mu''^2}$$

so both contributions matter. If you want to build a choke for HF (High Frequency), you should look for ferrite with high μ from 1.8 to 30MHz. From the Fair-Rite website,

@1,8 MHz $\mu'=911$ e $\mu''=182$

@ 16 MHz $\mu'=205$ e $\mu''=276$

@ 30 MHz $\mu'=117$ e $\mu''=202$



Immagine presa dal sito Fair-Rite

1) Choosing the best ferrite

Image taken from the Fair-Rite website.

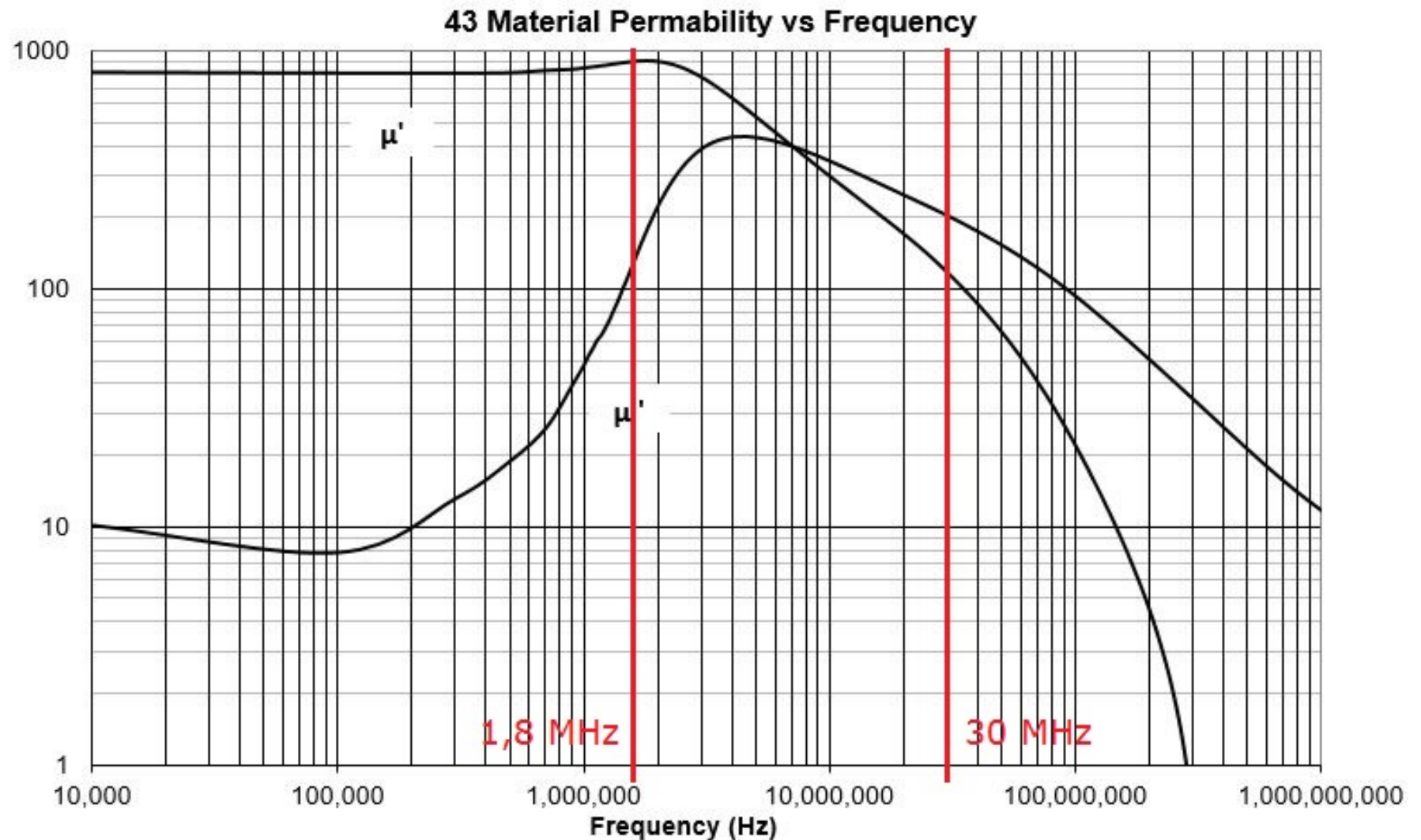
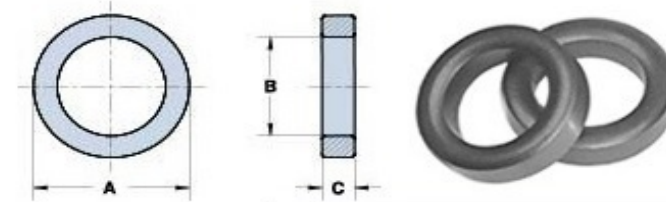

Grade #43 ferrite comes in various shapes. Ham radio operators primarily use the toroidal form, particularly the FT140 or FT240.

The two differ in their outer diameter, with the FT140 measuring 1.4 inches while the FT240 is 2.4 inches, or 61.00 mm.

For our project, we will use the larger-diameter ferrite, the FT240-43, which has an $A_e = 1.58$ cm².

On this ferrite, you can wind up to 17 turns of 5 mm coaxial cable, with the average length of a turn being 70mm.

Dimensions: Top numbers are in millimeters, bottom numbers are in inches

Low-Medium Permeability, 43 ($\mu_i=800$) material

Part Number	Frequency Range	A	B	C	Wt. (g)	A_L (nH)	A_e (cm ²)	l_g (cm)	V_g (cm ³)
5943011101	43 Material	073.65 ±1.50 (2.900")	38.85 ±0.75 (1.530")	12.70 ±0.40 (0.500")	188	1300 ±25%	2.14	16.5	35.3
5943003821	43 Material	062.80 Max (2.472" Max)	34.20 Min (1.347" Min)	13.70 Max (0.539" Max)	106	1075+20%, -25%	1.58	14.5	22.8
5943003801	43 Material	061.00 ±1.30 (2.400")	35.55 ±0.85 (1.400")	12.70 ±0.50 (0.500")	120	1075 ±20%	1.58	14.5	22.8
5943017301	43 Material	047.50 ±1.20 (1.902")	31.50 ±0.80 (1.252")	19.05 ±0.35 (0.750")	94	1275 ±25%	1.55	12.2	18.9
5943018601	43 Material	043.60 ±1.00 (1.717")	23.10 ±0.50 (0.909")	18.00 ±0.50 (0.709")	90	1830 ±25%	1.78	9.8	17.5
5943002721	43 Material	036.80 Max (1.449" Max)	21.95 Min (0.864" Min)	13.70 Max (0.539" Max)	33	885+20%, -25%	0.78	8.9	7
5943002701	43 Material	035.55 ±0.75 (1.400")	23.00 ±0.55 (0.906")	12.70 ±0.50 (0.500")	33	885 ±20%	0.78	8.9	7

2) Determining the minimum number of turns

To determine the minimum number of turns (N_{min}), you need to decide the minimum attenuation (IL_{min}) you want to achieve with the choke and the minimum frequency (f_{min}) at which it should occur. The mathematical calculation can be quite complex, but it can be simplified using a VNA and a clever trick.

The trick is to measure with a VNA the impedance of a narrow loop wound around the ferrite you want to use at the minimum frequency. Here are the steps:

- A. Measure the resistance (R_1) and reactance (X_1) of a loop at the frequency f_{min} using the VNA;
- B. Calculate the modulus of the impedance Z_1 of the loop with R_1 and X_1 : $Z_1 = \sqrt{R_1^2 + X_1^2}$ [Ω];
- C. Now, you need to determine the minimum impedance (Z_{min}) that your choke must have to achieve the desired attenuation IL_{min} . To find this value, you'll need to perform the following calculation:

$$Z_{min} = 100 \left(10^{\frac{IL_{min}}{20}} - 1 \right) \quad [\Omega];$$

- D. Once you know Z_{min} , you can calculate the minimum number of turns to wind: $N_{min} = \sqrt{\frac{Z_{min}}{Z_1}}$.

The minimum attenuation (IL_{min}) should never be less than 20dB, although it's better to aim for 30dB. Thirty dB means attenuating common mode currents by a factor of 1000.

2) Determining the minimum number of turns

EXAMPLE

We want to create a choke for HF, from 3.5MHz to 30MHz, with a minimum attenuation (IL_{min}) of 30dB using an FT240-43 ferrite.

A. With a VNA, we measure the impedance of a single turn at the minimum frequency of 3.5MHz, and we obtain $R_1=8,98 \Omega$ e $X_1=16,6 \Omega @3,500\text{MHz}$;

B. The modulus of the impedance $Z_1 = \sqrt{R_1^2 + X_1^2} = \sqrt{8,98^2 + 16,6^2}=18,87 \Omega$;

C. The desired minimum attenuation IL_{min} is 30dB, so the minimum impedance to be achieved with the choke is:

$$Z_{min} = 100 \left(10^{\frac{IL_{min}}{20}} - 1 \right) = 100 \left(10^{\frac{30}{20}} - 1 \right) = 3062 [\Omega];$$

D. The minimum number of turns to wind is: $N_{min} = \sqrt{\frac{Z_{min}}{Z_1}} = \sqrt{\frac{3062}{18,16}} = 12,74$ turns.

Rounding up to the nearest whole number and adding one for safety, you should wind 14 turns.

3) Selecting the coaxial cable

The choice of coaxial cable is strategic because all the power is carried by the coaxial cable. Furthermore, the coaxial cable will need to be wound around our toroid, so the minimum bending radius should be at least 8mm. Otherwise, the same phase delay at all frequencies or even the characteristic impedance Z_0 of the line may not be guaranteed. For this reason, coaxial cables with a solid and compact dielectric are preferred.

I have extracted the necessary data for the selection from the Huber+Suhner catalog.

Sigla	Z_0	D_e [mm]	VF	V_{max} [Vrms]	R min. [mm]	P_{max} [W]	P_{max} [W]
RG 58 C/U	50 +/-2	4,95	0,66	2500	25	105 @1GHz	606 @30MHz
RG 142 B/U	50 +/-2	4,95	0,69	2500	30	407 @1GHz	2350 @30MHz
RG 316 /U	50 +/-2	4,95	0,69	1500	15	135 @1GHz	779 @30MHz
SUCOFORM 141 FEP	50 +/-2	4,10	0,71	1900	8	560 @1GHz	3233 @30MHz

The maximum CW power is provided by the manufacturer at a frequency of 1GHz. To determine it at different frequencies, you need to apply the following formula:

$$P_f = \frac{P_{max @1GHz}}{\sqrt{f}}$$

Where the frequency f is expressed in GHz.

In the table, you can find the values already calculated for the highest frequency of use: 30 MHz. It is a good practice never to exceed 60-70% of the maximum power.

Finally, it's evident that the cable to choose is the semi-rigid SUCOFORM 141 FEP. It meets all the project requirements: $Z_0 = 50$ ohms; $R_{min} = 8$ mm, and $P_{max} > 500W @30$ MHz.

4) Selecting the coaxial cable

43 Material Data Sheet

This NiZn is our most popular ferrite for suppression of conducted EMI from 20 MHz to 250 MHz. This material is also used for inductive applications such as high frequency common-mode chokes.

Property	Unit	Symbol	Value
Initial Permeability@ B < 10 gauss		μ_i	800
Flux Density @ Field Strength	Gauss Oersted	B H	3500 10
Residual Flux Density	Gauss	B_r	2200
Coercive Force	Oersted	H_c	0.36
Loss Factor @ Frequency	10^{-6} MHz	$\text{Tan } \delta / \mu_i$	100 1.0
Temperature Coefficient of Initial Permeability (20 -70°C)	%/°C		1.25
Curie Temperature	°C	T_c	>130
Resistivity	ohm-cm	ρ	1×10^5

4) Verifying the ferrite

The grade #43 ferrite allows for a maximum flux density of 350 mT (1 mT = 10 Gauss).

The formula for calculating the flux in a toroid is that of transformers:

$$B_{Max} > \frac{10 \cdot V_{eff}}{\sqrt{2} \pi f \cdot n_p \cdot A_e} \text{ [mT]}$$

If the frequency f is in [MHz], the area A_e is in [cm²], the result will be in [mT].

However, it's not straightforward to know the effective voltage V_{eff} to which our choke is subjected. The common mode current is not known in advance. We do know, though, that it cannot exceed the differential mode current. But if the common mode current were equal to the differential current, we would have an abnormal operation or a fault; a condition that cannot be ruled out. So, we will perform the calculation assuming that the common mode current is equal to the differential current.

The legal power limit in Italy is $P_{leg} = 500\text{W}$, so the effective voltage on the choke will be:

$$V_{eff} = \sqrt{Z_0 \cdot P_{leg}} = \sqrt{50 \cdot 500} = 158 \text{ V}$$

Therefore, we perform the calculation knowing from the ferrite datasheet that $A_e = 1.58 \text{ cm}^2$:

$$B_{Max} > \frac{10 \cdot V_{eff}}{\sqrt{2} \pi f \cdot n_p \cdot A_e} = \frac{1580}{4,44 \cdot 3,5 \cdot 13 \cdot 1,58} = 4,95 \text{ mT. Which is much lower than the maximum of 350mT.}$$